

User's Manual



Dump Truck



CEEC TRUCKS

Whatsapp: +86 136 4729 9000
+86 159 7192 0800

OWNER'S MANUAL

Preface

Thank you for purchasing our products. For better using your ISUZU all-wheel drive Dump Truck, get the best operating performance, we strongly suggest that before the operation process you should read this manual instructions carefully, and to manipulate the program handily.

The manual detailed describes the performance of dump truck, structure, usage, precautions and maintenance of such knowledge. While showing details of the truck, both pictures and description will together help you get better understanding of how to use truck. Before the operation, the skilled operator should carefully read the contents of the manual.

After master the truck performance characteristics, methods of operation and precautions, then could start to operate this dump truck. In order to ensure the staff turnover after the operation, and properly use of the truck. This manual book must be properly kept, shall not be lost and damage.



CEEC TRUCKS

Whatsapp: +86 136 4729 9000
+86 159 7192 0800

Contents

Chapter 1. General Description.....	5
Chapter 2, Main Technical Data	6
Chapter 3, What is Dump Truck.....	7
i , Dump Truck Basic Structure	7
ii , Dump Truck Working Principle.....	8
iii, Dump Truck Off-Road Function Notice (Important).....	9
Chapter 4, How to Operate Dump Truck.....	11
i ,Dump Truck Introduction.....	11
Whatsapp: +86 136 4729 9000 +86 159 7192 0800	
ii ,Dump Truck Operation Guidance (Very Important)	12
Chapter 5, Others for Attention	15
Chapter 6 Troubleshooting.....	16

Chapter 1. General Description

*Our off-road Dump Truck based on type II ISUZU 4*4 LHD chassis; tipper body capacity could up to 3 tons. The truck use hydraulic system and mechanical system to realize truck good self-discharging function. Trucks widely used in city, mining area, construction area, etc.*

*The vehicle designed to fully rely on the advantages of the original 4*4 left-hand-drive chassis, fully consider the product's convenience, reliability and features. The tipping model can be optional as rear tipping system and side tipping system, which use operation valve to control hydraulic cylinder working. The tipper body material is international standard high strength steel, all with anti-rust painting, which can effective to avoid rusting.*

*The ISUZU 4*4 Dump Truck equipped with high quality dump body and middle hydraulic lifting cylinders, which loading capacity can be 3Tons. The dump trucks widely used together with excavator trucks, loading trucks and belt conveyor machine. Therefore, the dump truck is an ideal Construction Truck mainly for heavy duty goods loading & transportation.*



(Preview for your ISUZU 3Tons Dump Truck)

Chapter 2, Main Technical Data

Basic parameter:

Items		4x4 ISUZU Dump Truck
S I Z E	Outer Dimension (L×W×H) (mm)	5500*1900*2400
	Wheelbase (mm)	3360
Kerb Weight (kg)		3100
G E A R	Gearbox brand	ISUZU MSB
	Model	5-shift gearbox
	Type	Manual
Cab capacity (includes driver)		2
E N G I N	Model	ISUZU 4KH1-TCG40
	Type	Four cylinder inline, water-cool, turbocharged Inter-cooling, diesel
	Rating Power (kW/HP)	88/120
	Emission Standard	Euro 4

Note: 1. The vehicle height includes tipper body front fence.

2. We keep the right to revise the parameters on the list above.

Dump System basic parameter list

Whatsapp: +86 136 4729 9000
+86 159 7192 0800

Items		Parameter	
Control System		Hydraulic control system	
Hydraulic Lifting		Middle lifting device	
Garbage Container	Capacity (Ton)	3	
	Material	High Strength Carbon Steel	
	Painting	Internal	With anti-rust painting
		External	White painting
	Dimension	Length (mm)	3300
		Width (mm)	2200
Height (mm)		550	

Chapter 3, What is Dump Truck

i , Dump Truck Basic Structure

We produced dump truck also named tipper truck, self-discharging truck. This based on famous ISUZU brand truck chassis, refitted with special upper structure. And the components consist of Hydraulic Lifting Device, Dump Body, Auxiliary Frame and Spare Parts. Sample technical drawing with component as following:

Hydraulic Lifting Device: This device including gear pump, lifting valve, hydraulic oil pipeline system, lifting device, position-limit mechanism.

Dump Body: Which material is high strength carbon steel, including front plate, side plate, bottom plate, rear plate, and rear door switching mechanism.

Auxiliary Frame: Which material is high strength carbon steel, including longitudinal frame, transverse frame, lifting shaft, and welding place to main frame.

Spare Parts: This including safety jackstay, position-limit device and balance support.

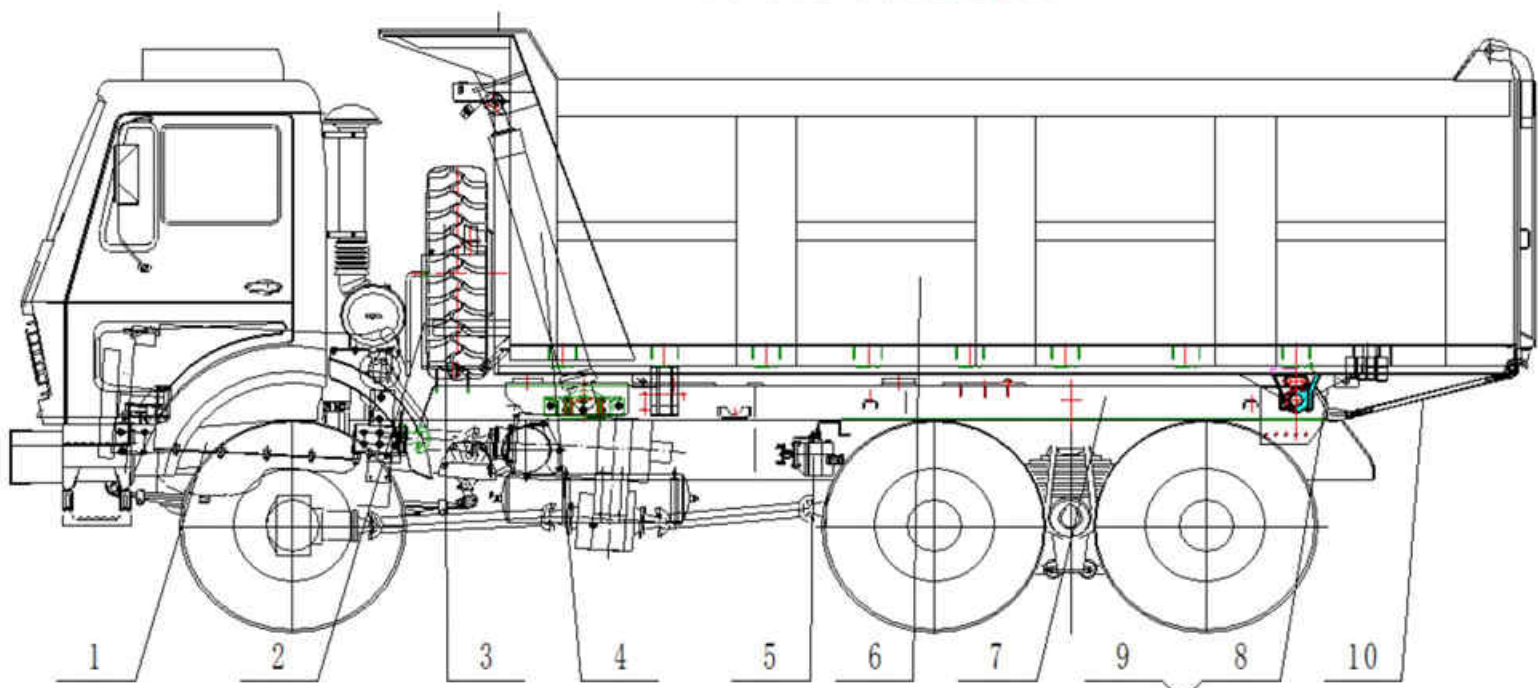

Sample Drawing for Dump Truck (6x4 model)

- 1、 ISUZU Chassis 2、 Hydraulic Oil System 3、 Spare Tire Device 4、 Hydraulic Lifting Device
- 5、 Gear Pump Assembly 6、 Dump Body Assembly 7、 Auxiliary Frame Assembly 8、 Mudguard Assembly
- 9、 Rear Lamp Assembly 10、 Body Lock Device (Rear Door Switching Device)

ii, Dump Truck Working Principle

As for hydraulic lifting system, which including control valve, PTO, gear pump, transmission shaft, hydraulic oil cylinder, hydraulic oil tank, oil pipeline, position-limit valve, etc.

The PTO (Power Take Off) gets power from Truck Engine, then transit power to Gear Pump through transmission shaft, the Gear Pump start working, Control Valve can control the hydraulic cylinder working, which can make dump body up and down working, then realize the self-discharging function.

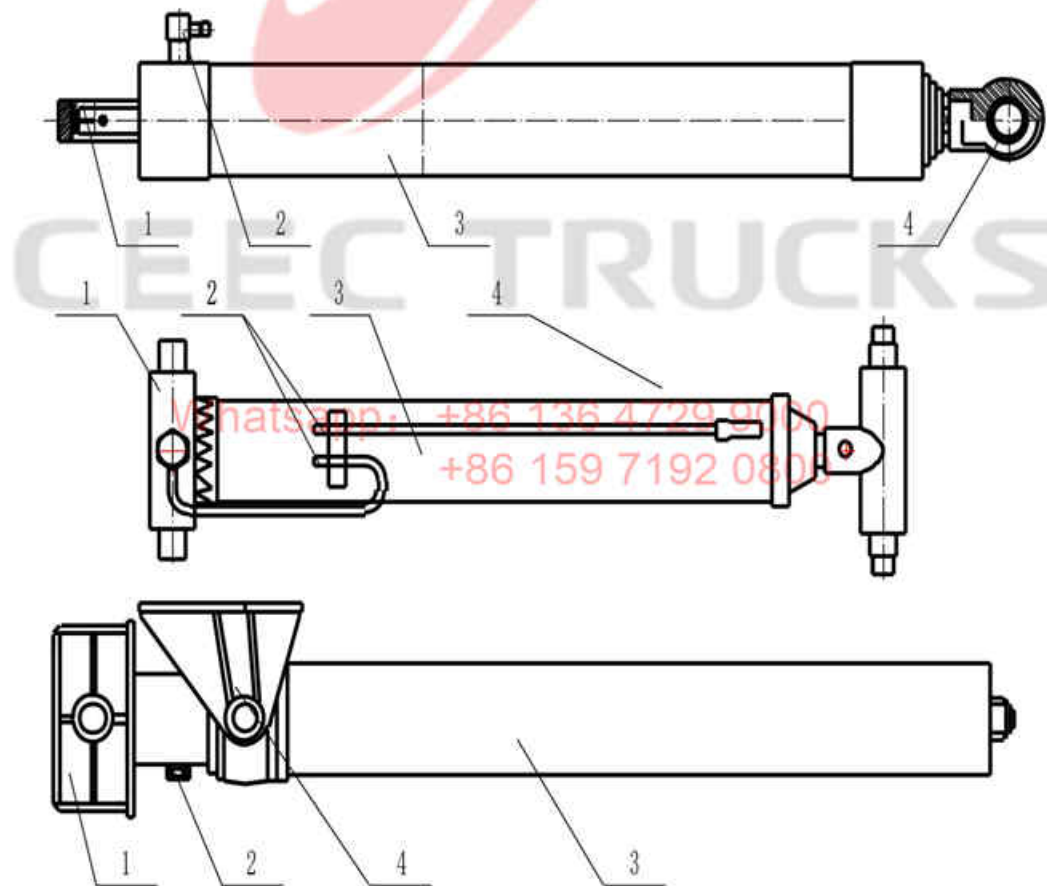

Hydraulic cylinder

- 1、 Lower Installation Seal 2、 Pipeline Connector Head 3、 Cylinder Body 4、 Upper Installation Seat

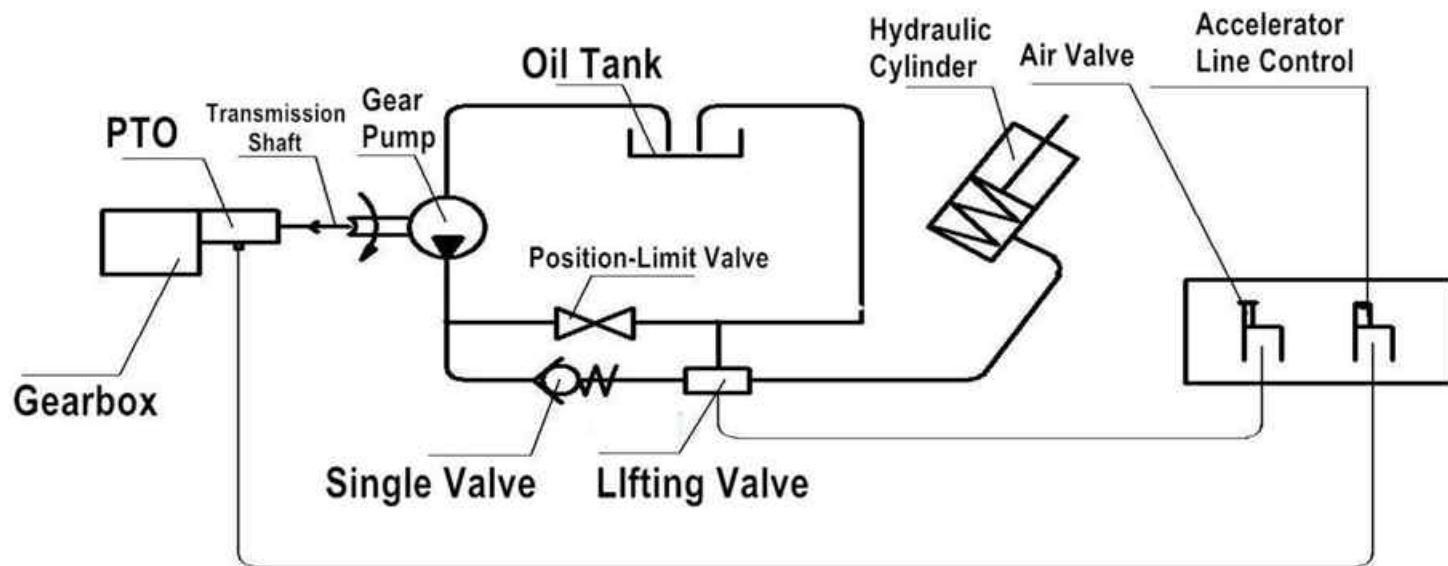

Hydraulic Lifting System working diagram

iii, Dump Truck Off-Road Function Notice **(Important)**

Truck with Off-road functions mainly used in bad road conditions, with recommend speed not too high.

1. Off-road truck not allowed driving with speed over 50km/h. If speed at 50km/h, truck should stop for one hour after 3~4 hours continue driving, which can dissipate heat from the gearbox. Carefully checking gearbox air hole after long time driving, if have oil overflow, which means the gearbox temperature too high.

Whatsapp: +86 136 4729 9000

+86 159 7192 0800

2. Strictly avoid misoperation, Two Drive & Four Drive can be only operated when truck stopped. Because misoperation during driving will damage the axle. Make sure the control air cylinder right position during driving: Two Wheel Drive → Air Cylinder extend out; Four Wheel Drive → Air Cylinder retract back





Two Wheel Drive Model:
Air Cylinder **extend out**



Four Wheel Drive Model:
Air Cylinder **retract back**

3. *How to use Two Wheel Drive & Four Wheel Drive: Start the truck, Turn On the Air Pump till air pressure at least 8 bar,*



Air Pump button
LEFT: Turn Off
RIGHT: Turn On



Whatsapp: +86 136 4729 9000
+86 139 7192 0800

4. *Front Axle Maintenance: Add grease every week; Change new axle oil every 1500km / 3 months; Change new gearbox oil every 2000km(Oil volume approx. 4500ml)*

5. *No Overloading Operation: Recommend loading capacity is 3Tons. Strictly forbidden overloading.*

Chapter 4, How to Operate Dump Truck

i ,Dump Truck Introduction

Kindly refer to Chapter 3 and details for dump trucks showing as below.



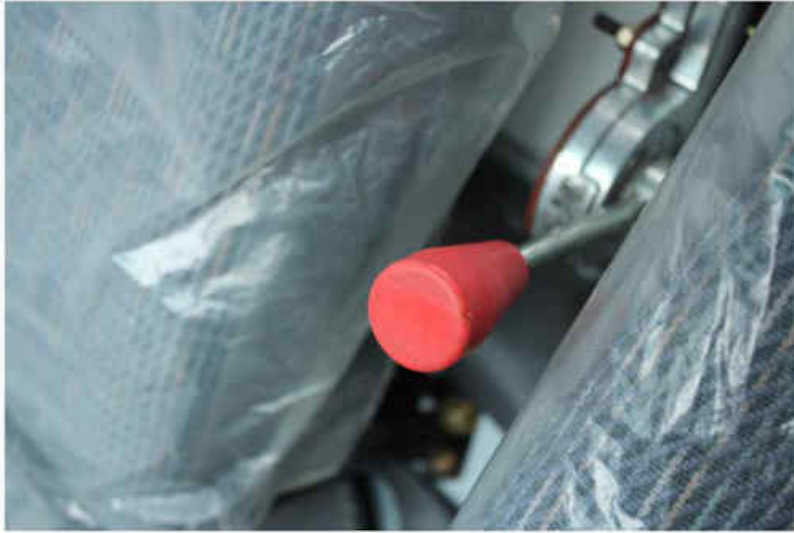

Higher Position: PTO OFF



Lower Position: PTO ON

ii ,Dump Truck Operation Guidance **(Very Important)**

1. *The Preparation for Operation:* Carefully checking the operation environment, make sure no person stand around the truck, also do not forget pull the Parking Brake before any operation.
2. *PTO Operation:* Before operating the dump system, please make sure the PTO is working. Detail operation process should as follow, firstly start the truck engine and depress the clutch panel, secondly close the PTO switch, thirdly slowly loosen the clutch panel, then the oil pump start working.

Whatsapp: +86 136 4729 9000
+86 159 7192 0800

Accelerator Switch line
Lower Position: PTO start working
Higher Position: PTO stop working

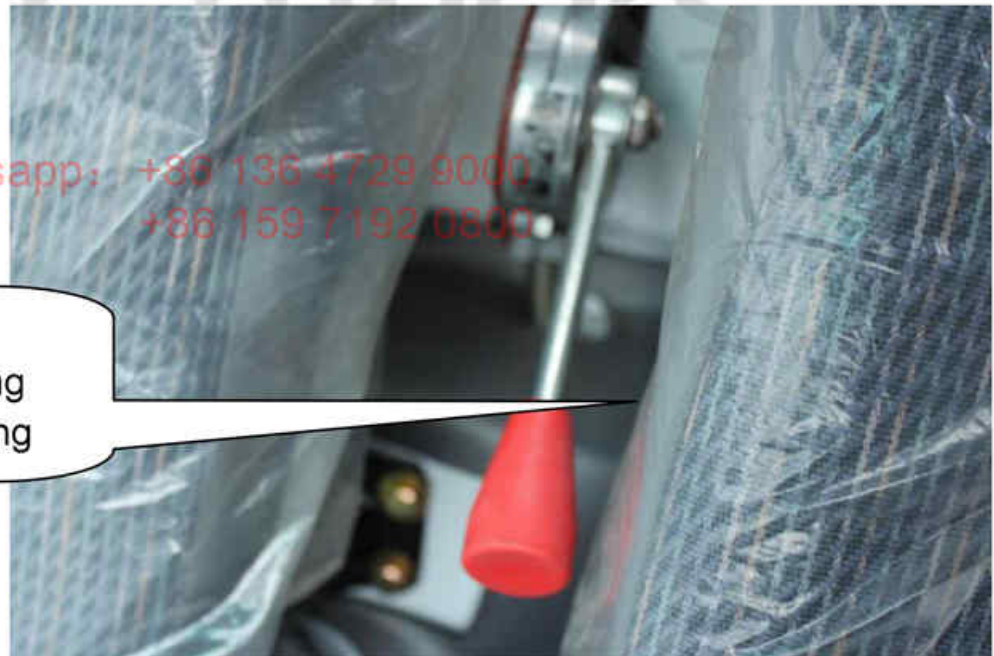

Lower Position: PTO ON

NOTE: Please keep the Accelerator handle Cable at Higher Position while driving the truck!
Please does not operating the dump system while driving the truck!

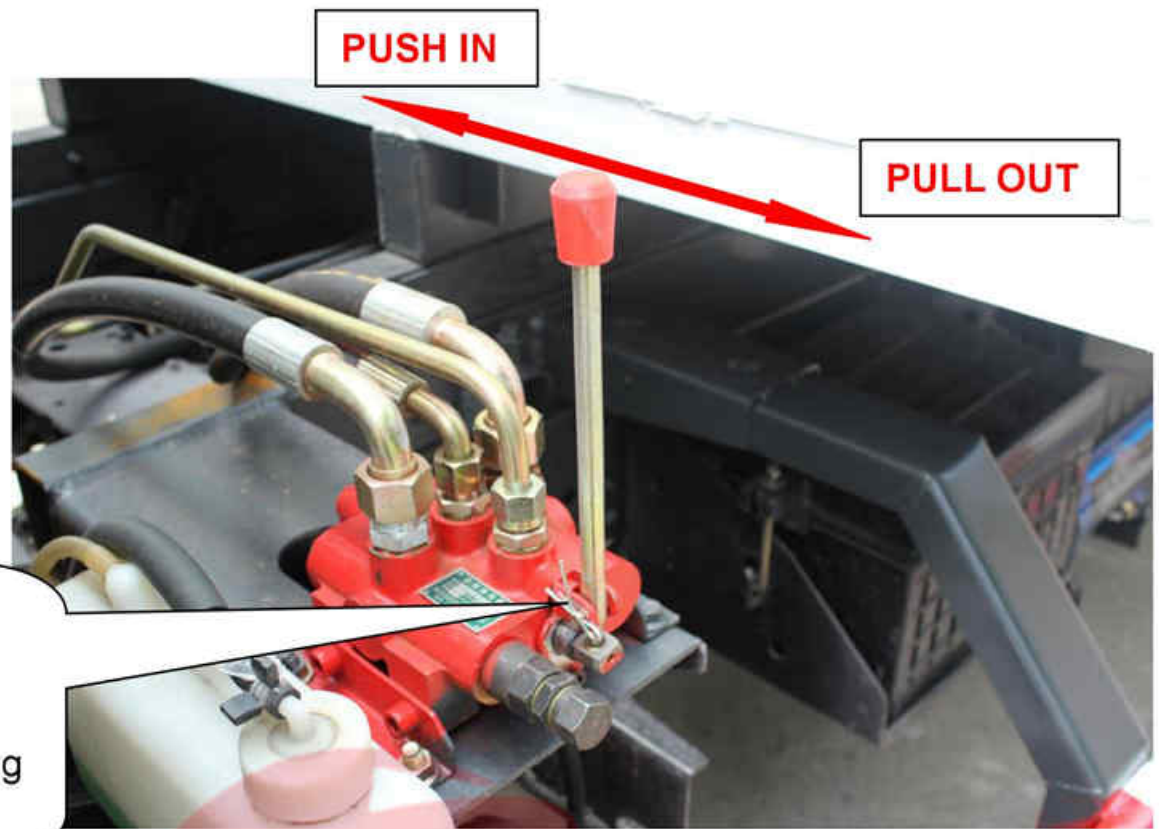

Control Device
 PULL OUT: Dump body lifting up
 PUSH IN: Dump body falling down

3. **Dump Truck Operation:** Carefully follow below guidance to operate your dump truck.

➤ **Start Up:**

Start truck engine, keep the vehicle stops (neutral gear), and press the Clutch Plate and same time PULL OUT Accelerator Switch line, then PTO start working.

➤ **Lifting:**

PULL OUT the Control Device, the dump body start lifting up, press the accelerator plate can make lifting process faster.

CEEC TRUCKS

Whatsapp: +86 136 4729 9000
 +86 159 7192 0800

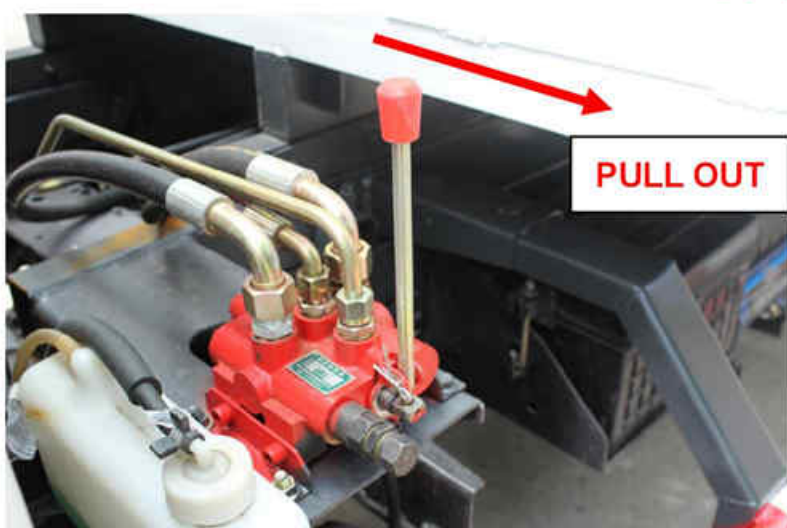

Operate the Control Device



Dump body lifting up

➤ **Falling:**

PUSH IN the Control Device, the dump body start falling down, press the accelerator plate can make falling process faster.



Operate the Control Device



Dump body falling down



Mechanical rear door lock, self-open/self-close during dump body lifting/falling process

Whatsapp: +86 136 4729 9000
+86 159 7192 0800



Both side plate and rear plate with manual lock for Open / Close

Chapter 5, Others for Attention

After carefully reading the above information, you must be well known how to use the ISUZU 4x4 Dump Truck; below show some parts you need to pay attention while using the truck.

- 1. The loaded materials should be distributed in the body, strictly forbidden overloading.*
 - 2. Keep nobody stand around when operating the dump truck.*
 - 3. Strictly forbidden the PTO on Working Position during the truck driving.*
 - 4. Strictly forbidden operate the Control Device during the truck driving.*
 - 5. Please keeps the dump truck in flat road during discharging working, strictly forbidden discharging working in a transverse slope.*
 - 6. During the whole loading and unloading process, the operator should not leave the Control Device, in case of there is an emergency.*
- Whatsapp: +86 136 4729 9000**
- 7. When truck stopped and ready for lifting work, operator should start the truck engine firstly, and make the engine idle for 3~5 minutes, then following Chapter 4 for operation.*
 - 8. Make sure the truck engine idle, and then Accelerator Switch line can be UP POSITION to make PTO start working.*
 - 9. When dump body start for discharging working, release the accelerator plate when last level hydraulic cylinder extend, then engine rotation speed slowdown, which can reduce the dump body lifting of inertia. When dump body to maximum lifting angle, stop the gear pump to avoid any emergency.*

Chapter 6 Troubleshooting

Please kindly checking below possible troubleshooting, which just for your reference.

Malfunction	Possible Reason	Solution
Gear Pump broke down	<ol style="list-style-type: none"> 1. PTO on Working Position during driving, and make PTO idling long time 2. Hydraulic oil shortage, long time lifting 	<ol style="list-style-type: none"> 1. Make sure PTO on Driving Position 2. Add enough hydraulic oil
No-load body not lifting	<ol style="list-style-type: none"> 1. PTO on Driving Position 2. Hydraulic oil shortage 3. Gear pump broke down and not hydraulic oil supply 4. Control Valve keeps ON 5. Hydraulic oil polluted 	<ol style="list-style-type: none"> 1. Check the gear and make PTO on Working Position 2. Add enough hydraulic oil 3. Repair or replace new gear pump 4. Control Device air shortage, add enough air and check the seals. Replace new valve if necessary 5. Cleaning all hydraulic system parts and change new hydraulic oil
Full-load body not lifting	<ol style="list-style-type: none"> 1. PTO on Driving Position 2. Dump truck over loading 3. Lifting working process on rough road 	<ol style="list-style-type: none"> 1. Check the gear and make PTO on Working Position 2. Use the truck with rated loading weight 3. Lifting working on flat road
Dump body can lift a little, not to the maximum lifting angle	<ol style="list-style-type: none"> 1. Air pressure not enough 2. Hydraulic oil shortage 	<ol style="list-style-type: none"> 1. Cleaning all hydraulic system parts and change new hydraulic oil 2. Add enough hydraulic oil
Dump body lifting to an angle then start falling down automatically	<ol style="list-style-type: none"> 1. Hydraulic system leakage 	<ol style="list-style-type: none"> 1. Carefully check all hydraulic parts, fasten the pipeline or change new parts to solve leakage problem
There is a noise during lifting process	<ol style="list-style-type: none"> 1. Dump truck over loading 2. Lifting working process on rough road 	<ol style="list-style-type: none"> 1. Use the truck with rated loading weight 2. Lifting working on flat road